



PIT en1.0/PIT en1.1

PILZ
THE SPIRIT OF SAFETY

- ▶ Control and signal devices

This document is the original document.

All rights to this documentation are reserved by Pilz GmbH & Co. KG. Copies may be made for the user's internal purposes. Suggestions and comments for improving this documentation will be gratefully received.

Source code from third-party manufacturers or open source software has been used for some components. The relevant licence information is available on the Internet on the Pilz homepage.

Pilz®, PIT®, PMI®, PNOZ®, Primo®, PSEN®, PSS®, PVIS®, SafetyBUS p®, SafetyEYE®, SafetyNET p®, the spirit of safety® are registered and protected trademarks of Pilz GmbH & Co. KG in some countries.



SD means Secure Digital

Introduction	4
Validity of documentation	4
Using the documentation	4
Definition of symbols	4
Safety	5
Intended use	5
Safety regulations	6
Use of qualified personnel	6
Warranty and liability	6
Disposal	6
For your safety	6
Unit features	6
Block diagram/terminal configuration	7
Function description	7
Wiring	7
Connection to evaluation device	8
Connection to PNOZ X, PNOZsigma, PNOZelog	8
Connection to PDP67 F 8DI ION	8
Connection to PNOZmulti	8
Connection to PSS with or without SafetyBUS p	8
Dimensions	9
Enabling switch	9
Bracket	9
Technical details	10
Safety characteristic data	12
Order reference	12
Product	12
Accessories	12
EC declaration of conformity	12

Introduction

Validity of documentation

This documentation is valid for the product PIT en1.0/PIT en1.1. It is valid until new documentation is published.

This operating manual explains the function and operation, describes the installation and provides guidelines on how to connect the product.

Using the documentation

This document is intended for instruction. Only install and commission the product if you have read and understood this document. The document should be retained for future reference.

Definition of symbols

Information that is particularly important is identified as follows:



DANGER!

This warning must be heeded! It warns of a hazardous situation that poses an immediate threat of serious injury and death and indicates preventive measures that can be taken.



WARNING!

This warning must be heeded! It warns of a hazardous situation that could lead to serious injury and death and indicates preventive measures that can be taken.



CAUTION!

This refers to a hazard that can lead to a less serious or minor injury plus material damage, and also provides information on preventive measures that can be taken.



NOTICE

This describes a situation in which the product or devices could be damaged and also provides information on preventive measures that can be taken. It also highlights areas within the text that are of particular importance.

**INFORMATION**

This gives advice on applications and provides information on special features.

Safety**Intended use**

The enabling switch is a manually operated control device, which can be used as an enabling device when automated production equipment is used in manual mode. Authorised personnel can access the danger zone while movable guards are open, to monitor workflows or carry out setup or maintenance work.

Each person accessing the danger zone must be equipped with an enabling switch.

Only evaluation devices that monitor for shorts across contacts may be used. As evaluation devices we recommend the devices described under [Connection to evaluation device](#) [ 8].

The enabling switch may **not** be used on its own to switch on a potentially hazardous condition.

The enabling switch may **not** be used in place of other safety measures.

**WARNING!****Risk of injury by manipulation or by defeating the enabling switch**

If the function of the enabling switch is taken out of service by manipulation, or if the enabling switch is defeated, this can lead to serious injury or death. Prevent manipulation or defeating of the enabling device by additional measures such as:

- Time limit for operation
- Renewed operation with each machine cycle

The following is deemed improper use in particular:

- ▶ Any component, technical or electrical modification to the product
- ▶ Use of the product outside the areas described in this manual
- ▶ Use of the product outside the technical details (see chapter entitled "[Technical details](#)" [ 10]).

Safety regulations

Use of qualified personnel

The products may only be assembled, installed, programmed, commissioned, operated, maintained and decommissioned by competent persons.

A competent person is a qualified and knowledgeable person who, because of their training, experience and current professional activity, has the specialist knowledge required. To be able to inspect, assess and operate devices, systems and machines, the person has to be informed of the state of the art and the applicable national, European and international laws, directives and standards.

It is the company's responsibility only to employ personnel who

- ▶ Are familiar with the basic regulations concerning health and safety / accident prevention,
- ▶ Have read and understood the information provided in the section entitled Safety
- ▶ Have a good knowledge of the generic and specialist standards applicable to the specific application.

Warranty and liability

All claims to warranty and liability will be rendered invalid if

- ▶ The product was used contrary to the purpose for which it is intended,
- ▶ Damage can be attributed to not having followed the guidelines in the manual,
- ▶ Operating personnel are not suitably qualified,
- ▶ Any type of modification has been made (e.g. exchanging components on the PCB boards, soldering work etc.).

Disposal

- ▶ When decommissioning, please comply with local regulations regarding the disposal of electronic devices (e.g. Electrical and Electronic Equipment Act).

For your safety

- ▶ Check the function of the pushbutton before commissioning for the first time and then at regular intervals (at least annually).

Unit features

The enabling switch is enclosed in plastic housing.

Features:

- ▶ 3-stage pushbutton (off - on - off)
- ▶ 1 signal contact
- ▶ Connection PIT en1.0p: Cable (5 m) with 5-pin M12 angled connector
- ▶ Connection PIT en1.0a: 6-core open-ended cable (5 m)
- ▶ Connection PIT en1.1a: 6-core open-ended coiled cable (5 m)
- ▶ Integrated magnetic clamp to attach the enabling switch to the machine, for example

Block diagram/terminal configuration

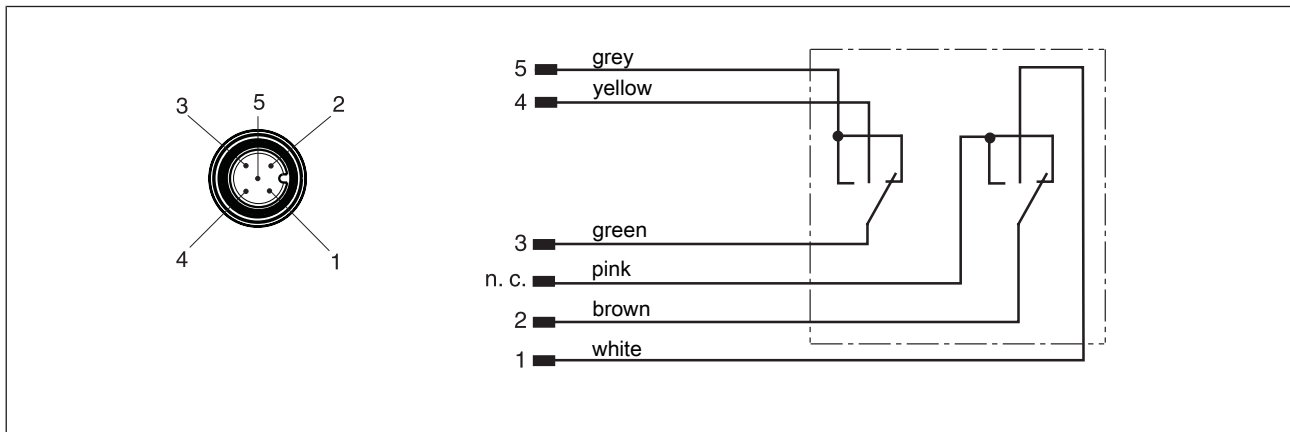

Function description

The switch is a 3-stage enabling switch:

- ▶ Not operated: no enabling signal (off)
- ▶ Operated as far as middle setting: enabling signal activated (on, enabling function)
- ▶ Operated as far as end stop: no enabling signal (off, panic function)

This guarantees that the enabling signal is interrupted not only when the switch is released but also when it is fully operated.

If the enabling switch is fully operated as far as the end stop and then released, it will remain switched off during the changeover.

Wiring

When wiring, please note:

- ▶ Protect the cables from damage, by using a protective tube for example.
- ▶ Use shielded cables and connect the shield to the plant/machine's protective earth system.

Connection to evaluation device

Connection to PNOZ X, PNOZsigma, PNOZelog

PNOZ e1p PNOZ e1.1p PNOZ e1vp PNOZ e6.1p PNOZ e6vp PNOZ s3 PNOZ s4	PNOZ s5 PNOZ X2C PNOZ X2 PNOZ X2.7P PNOZ X2.8P PNOZ X2.9P	
PNOZ e5.11p		
PNOZ X3.1 PNOZ X3P PNOZ X3 PNOZ X3.10P PNOZ XV2 PNOZ XV2P PNOZ XV3 PNOZ XV3P		

Connection to PDP67 F 8DI ION

The connection is made via the adapter PSEN mag ad (see operating manual PSEN adapt PSS67/PDP67 4p).

Connection to PNOZmulti

Safety gate with switch type 3 I0, I1: Inputs T0, T1: Test pulse outputs	
--	--

Connection to PSS with or without SafetyBUS p

Safety gate with switch type 3 I0, I1: Inputs O16, O17: Test pulse outputs	
--	--

We recommend that you use the standard function block SB064 or SB066 for connecting to a PSS.

Dimensions

Enabling switch

Dimensions with PIT en1.0p-5m-s as an example. The dimensions of the pushbutton housing and the cable length are identical with all variants (see [Technical details \[10\]](#))

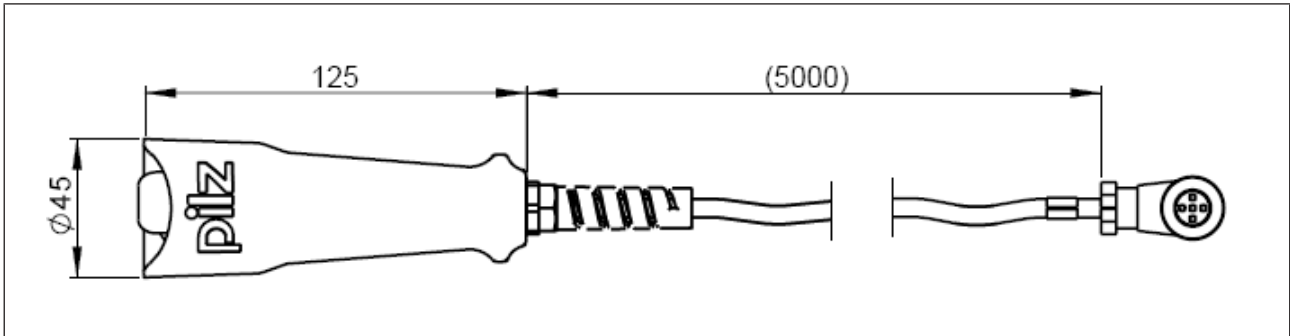

Bracket

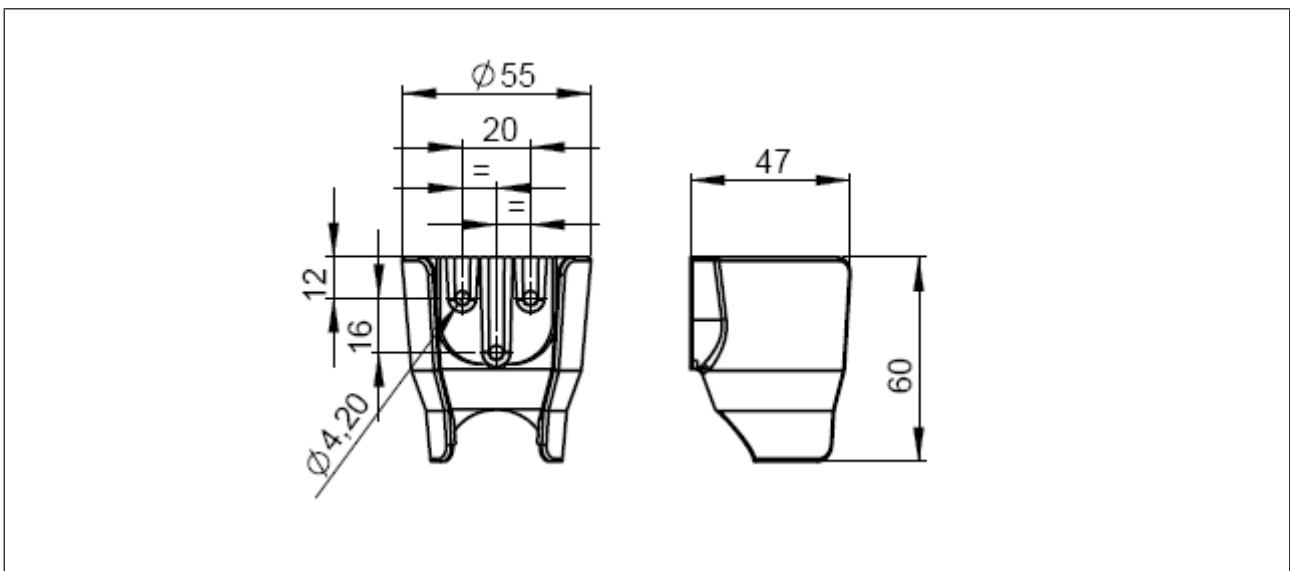

Technical details

General	401110	401111	401112
Certifications	CE	CE	CE
Self-monitored	No	No	No
Electrical data	401110	401111	401112
Max. switching current, safety contacts	1 A	1 A	1 A
Relay outputs	401110	401111	401112
Utilisation category			
In accordance with the standard	EN 60947-5-1	EN 60947-5-1	EN 60947-5-1
Utilisation category of safety contacts			
AC15 at	125 V	125 V	125 V
Max. current	0,3 A	0,3 A	0,3 A
DC13 (6 cycles/min) at	30 V	30 V	30 V
Max. current	0,7 A	0,7 A	0,7 A
DC12 at	30 V	30 V	30 V
Max. current	1 A	1 A	1 A
Environmental data	401110	401111	401112
Ambient temperature			
Temperature range	0 - 50 °C	0 - 50 °C	0 - 50 °C
Storage temperature			
Temperature range	-20 - 50 °C	-20 - 50 °C	-20 - 50 °C
Rated insulation voltage	125 V	125 V	125 V
Protection type			
Housing	IP65	IP65	IP65
Mechanical data	401110	401111	401112
Cable length L1	5 m	5 m	–
Cable length spiral extended	–	–	5 m
Cable length spiral closed	–	–	1,25 m
Cable insulation material K1	PUR	PUR	PUR
Cable diameter	6,2 mm	6,2 mm	5,4 mm
Outside diameter spiral	–	–	19,8 mm
Mounting position	Any	Any	Any
Connection type	M12, 5-pin male connector, angled	5 m cable	5 m coiled cable
Material			
Bottom	PP	PP	PP

Mechanical data	401110	401111	401112
Dimensions			
Height	125 mm	125 mm	125 mm
Width	45 mm	45 mm	45 mm
Depth	45 mm	45 mm	45 mm
Diameter of pushbutton	45 mm	45 mm	45 mm
Weight	383 g	361 g	470 g

Safety characteristic data



NOTICE

You must comply with the safety characteristic data in order to achieve the required safety level for your plant/machine.

Safety characteristic data	
B10d in accordance with EN ISO 13849-1:2015 and EN 62061	100.000
Lambda _d /Lambda in accordance with EN 62061	0,50

Order reference

Product

Product type	Features	Order no.
PIT en1.0p-5m-s	Cable (5 m) with 5-pin M12 angled connector	401 110
PIT en1.0a-5m-s	6-core open-ended cable (5 m)	401 111
PIT en1.1a-5m-s	6-core open-ended coiled cable (5 m)	401 112

Accessories

Product type	Features	Order no.
PIT en1.0 holder	Bracket for enabling switch	401 201

EC declaration of conformity

This/(These) product(s) fulfil the requirements of the low voltage directive 2006/95/EG. The complete EC Declaration of Conformity is available on the Internet at www.pilz.com/downloads.

Representative: Norbert Fröhlich, Pilz GmbH & Co. KG, Felix-Wankel-Str. 2, 73760 Ostfildern, Germany